

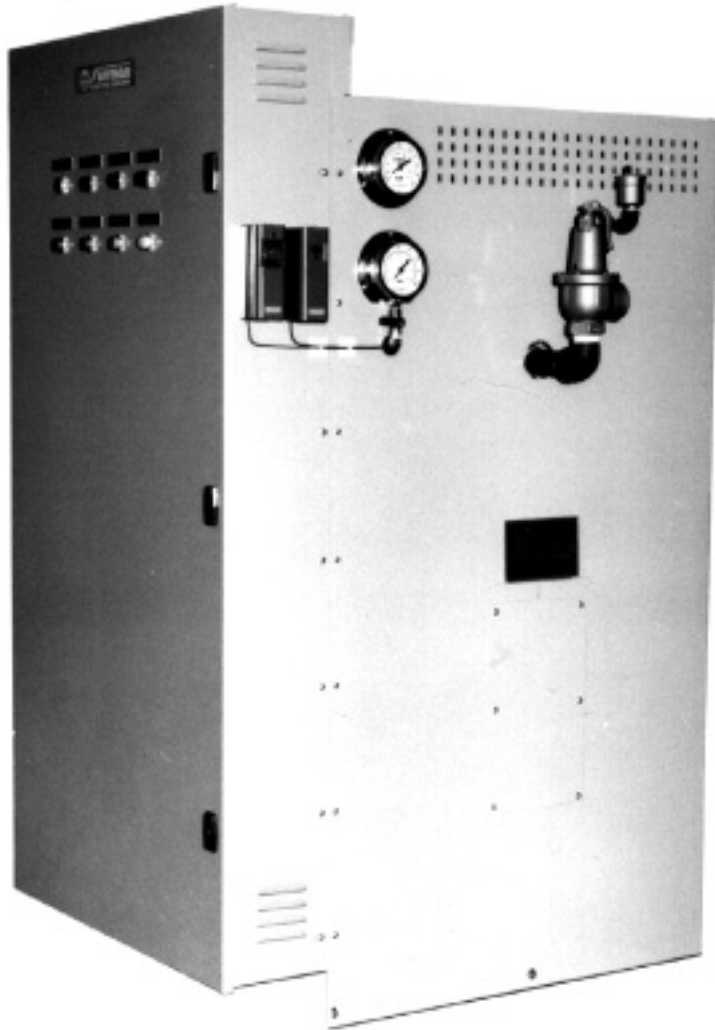

Series SVW Hot Water Boiler

Installation, Operation, Maintenance Manual & Spare Parts List



Model No. _____
 Boiler Serial No. _____
 National Board No. _____
 Safety Valve Set Pressure _____ PSIG
 Power Circuit Voltage _____
 Control Circuit Voltage _____
 Amps ____ Phase ____ HZ ____

TABLE OF CONTENTS

Scope 1.0
 Operating Principles & Specifications .. 2.0
 Installation..... 3.0
 Start-Up and Operation 4.0
 Maintenance 5.0
 Drawings 6.0
 Spare Parts..... 7.0
 Trouble Shooting..... 8.0
 Warranty 9.0

IMPORTANT NOTE:

As you follow these instructions, you will notice warning and caution symbols. This blocked information is important for the safe and efficient installation and operation of electric boilers. These are two types of potential hazards that may occur during this installation and operation:

 **WARNING** states a hazard which may cause serious injury or death if precautions are not followed.

 **CAUTION** signals a situation where minor injury or product damage may occur if you do not follow instructions.

IMPORTANT NOTE:

This highlights information that is especially relevant to a problem-free installation.



A Division of Sussman-Automatic Corporation
 43-20 34th Street, Long Island City, NY 11101 • (718) 937-4500
 1-800-238-3535 • Fax: (718) 937-4676 • email: seb@sussmancorp.com
 www.sussmanboilers.com

PUR 100434 Rev 1.1/11

1. Scope

This manual details the installation, operation and maintenance instructions, and spare parts list for Sussman Series SVW Hot Water Boilers.

Refer to section 6.0 for specific drawings and bills of material for related equipment supplied under this order.

Sussman hot water boilers are designed and manufactured to meet A.S.M.E. and code regulations. When properly operated and maintained, you can expect years of trouble free service.

Carefully follow the instructions outlined in this manual to ensure proper installation and performance of your boiler.

2. Operating Principles and Specifications

Sussman electric hot water boilers provide safe, versatile, easy to use heat sources for low or high pressure hot water in industrial, commercial, or space heating applications.

2.1 Principles of Operation

2.1.1 Sussman SVW electric hot water boilers utilize state of the art technology, control components, valves and accessories. The Series SVW features vertically positioned heating elements which have many advantages over horizontally positioned elements:

- a. Since the elements are removed from the top, the boiler requires less space.
- b. Vertical hot water boiler elements are less prone to scale build-up, a major cause of element failure.
- c. Boilers with vertical elements, being more compact, have faster response time than boilers requiring larger vessels.

2.1.2 Electric boiler operation:

- a. A steel vessel is fitted with tubular resistance type heating elements, inlet and outlet connections, a drain/blowdown valve(s), an air vent, a water control mechanism, a pressure relief valve, and a temperature control. These devices are configured with a series of electrical controls for automatic operation.
- b. When the boiler is switched on, an electronic level sensor first detects if a low water level condition exists.
If the sensor detects a low water level condition, the heaters will not energize until water is introduced through the piping system at the boiler inlet.
If a low water level condition does not exist, the sensor will activate the elements and immediately begin to heat the water.
- c. The air vent at the top of the boiler allows air to exit the boiler as it fills.

If air and other gases are not eliminated from the flow circuit, they may cause failure of the heating

elements and noise in the piping circuit.

- d. In forced recirculating systems, the necessary flow through the boiler is maintained by a circulation pump (by others).
For most calculation purposes, pressure drop through the boiler can be assumed to be the equivalent of 10 ft. of standard inlet piping size

Flow through the boiler enters at the inlet (bottom of the boiler) and exits through the outlet (top of the boiler).

- e. The boiler is controlled by sensing water temperature.
An adjustable temperature controller will switch off the heaters when the set temperature is reached. The temperature controller is backed up by a high limit temperature controller.

In the event that the boiler temperature overshoots the high limit set point, the controller will trip and de-energize all the heating circuits.

The high limit temperature controller must then be manually reset before the heaters will come back on.

Note: Cycling on the high limit is unacceptable. The cause of a high limit trip must be determined and rectified before resetting the limit.

- f. All boilers are fitted with a pressure relief valve which will open if the pressure approaches a set point chosen to be well below the withstand pressure of the boiler and system components.
- g. Drain and/or blowdown valve(s) located at the bottom of the boiler are provided for maintenance purposes. Boilers should preferably be installed with flanged connections or unions with stop valves on the inlet and outlet to allow the boiler to be drained without draining the entire system and to simplify servicing.
- h. Periodic inspections of the vessel interior will give advanced notice of an impending problem. The local boiler inspection authority is available for guidance in these instances.

2. Specifications (cont.)

2.2 Standard Boiler Accessories

The following shows the standard boiler accessories for SVW hot water boilers.

STANDARD BOILER ACCESSORIES

- | | |
|-----|--|
| No. | Description |
| 1 | Insulated ASME designed pressure vessel |
| 2 | Vented control cabinet |
| 3 | Pressure relief valve |
| 4 | Inspection and cleanout holes |
| 5 | Pressure gauge c/w isolating stopcock (not shown) |
| 6 | Air vent |
| 7 | Temperature gauge |
| 8 | Drain blowdown valve |
| 9 | Flanged heaters c/w low watt density elements |
| 10 | Control circuit on/off switch |
| 11 | Control circuit transformer (fused) |
| 12 | HRC power fusing |
| 13 | Magnetic contactors |
| 14 | Indicating pilot lights |
| 15 | Electronic low water control |
| 16 | Push to reset button for low water simulation |
| 17 | On/off staging up to 95 amps |
| 18 | Proportional temperature controller for units over 95 amps |
| 19 | Staging controller with detail no. 18 |
| 20 | High temperature controller |

FRONT VIEW

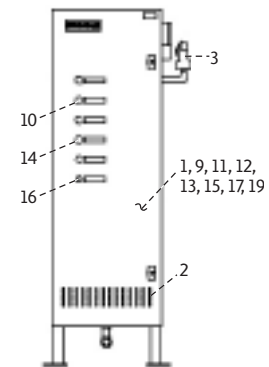

SIDE VIEW

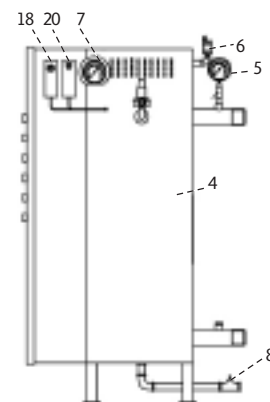

2.3 General Specifications

Listed below is a summary of the approximate piping sizes and volumes for the various standard boiler types and within this series. Minimum clearance requirements are shown in section 3.0.

STANDARD DESIGN PRESSURES ARE 100

PSIG (690 KPA) OR 160 PSIG (1104 KPA)

TABLE 1 - HOT WATER BOILER GENERAL SPECIFICATIONS

Up to Max. KW	Vessel Openings (NPT)		Normal Water Volume Gal. (Liters)
	Inlet/Outlet	Drain Valve	
144	2	3/4	5.3 (24)
202	2	3/4	11.3 (51.4)
585	4	1-1/4	46.5 (212)
1080	4	1-1/2	105 (478)
1890	8	1-1/2	206 (936)

2. Specifications (cont.)

2.4 Other Optional Equipment

Sussman offers the following as options for packaged hot water boiler systems.

Check to see that optional equipment has been supplied as ordered.

Inlet and outlet valves (gate)	Electronic progressive sequencer
Auxiliary low water cutoff	Motor starter
High temperature alarm	Ground fault indicator
Low temperature alarm	Spare components
Audible alarm c/w reset	Higher kW capacities
Pilot light per heating stage	Special voltages
Manual OFF/AUTO switch for heating stage	Higher pressure rating
Voltmeter c/w three position selector switch	Lined vessels (check factory)
Ammeter c/w three position selector switch	Indoor/outdoor temperature reset controller
kW hour meter	Auxiliary high temperature cutoff
Main power disconnect switch	High or low pressure cutoff
Main power automatic breaker	Flow switch
Safety door interlock switch	Proportional temperature controller (std. over 135 kW)

3. Installation

3.1 General

The boiler shall be installed by qualified personnel in accordance with the instructions contained in this manual. Furthermore, compliance with applicable National and local building and safety codes is necessary.

3.2 Pre-Installation

3.2.1 Inspect the boiler for possible damage due to shipping and handling. Claims for shipping damage shall be placed with the carrier, and should be reported immediately to them.

If damage has been sustained during shipping that may effect the safe and reliable operation of the boiler, contact the sales office to discuss corrective action.

For factory inquiries about this boiler, please have available the model number, serial number, voltage, kw, and phase of the supplied equipment. This information is available on the boiler nameplate.

Do not return the unit unless advised, since field repair may be the preferred course of action. Returns must include a Return Authorization available from Sussman.

3.2.2 Check the boiler nameplate data to ensure that it corresponds to the supply characteristics (i.e. - voltage, phase, frequency, wattage and pressure relief valve setting).

3.2.3 Consult local codes for specific requirements on the installation of the electric boiler.

3. Installation (cont.)

3.3 Mounting

3.3.1 The boiler must be positioned on an adequate base, preferably concrete, sufficient to support its in-service weight, and then levelled and secured in place.

3.3.2 Adequate clearance on all sides of the boiler is required for access and servicing. Please refer to the following diagram and table for minimum clearance

Up to Max kW	Minimum Clearances				
	A	B	D	E _L	E _R
144	30"	16"	24"	24"	24"
202	36"	22"	24"	24"	24"
585	36"	32"	24"	24"	24"
1080	48"	38"	30"	24"	30"
1890	48"	38"	30"	24"	30"

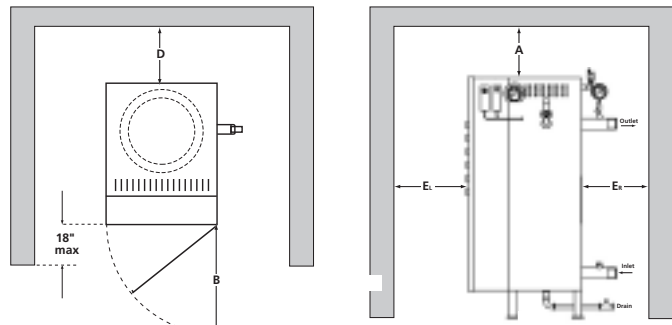

3.4 Plumbing

Refer to drawings in paragraph 6.1 for size and location of water inlet, outlet and other relevant openings. Ensure that all plumbing connections are made according to local regulations and applicable codes.

3.4.1 Inlet and Outlet

For single boiler installations, stop valves are normally required on the inlet and outlet connections of the boiler to allow the boiler to be drained and cleaned without having to drain the entire system.

When the boiler is located higher than the rest of the system, these valves may not be required. However, they are recommended.

For multiple boiler installations in a single system, stop valves are always required at the inlet and outlet piping connections.

For connection: Pipe the system return piping to the boiler inlet (at the bottom) and the system inlet piping to the boiler outlet (at the top). Never reverse the two.

3.4.2 Make-up Water

Make-up water may be introduced into the boiler through the return piping system. The make-up water piping requires a check valve and a stop valve. A fill valve may be utilized to control minimum system pressure.

For connection: Pipe the make-up water piping, through a check valve, then a stop valve at the system return

3.4.4 Pressure Relief Valve

The boiler is equipped with a pressure relief valve to prevent the boiler from exceeding the maximum allowable working pressure.

For connection: Pipe the outlet from the pressure relief valve to a suitable drain away from other equipment, walkways and personnel. Do not reduce the piping size from the pressure relief valve.

Do not install any other valves or plugs in this piping.

3.4.5 Slowdown Piping

Most jurisdictions prohibit the blow-off from the boiler from being directly discharged into the sewer system. However, in all

cases, you must check with local authorities to ensure compliance with local regulations prior to the connection of any blowdown piping to any sewer system.

For connection: Pipe the blowdown valve(s) to the inlet of a blowdown tank or a suitable drain (as appropriate).

3.4.6 Circulation Pumps

If a circulation pump (optional) was not supplied with your boiler, select a pump whose energy head exceeds the calculated energy head for the system at the design flow rate. Flow rate can be adjusted down with a globe valve.

For connection: Pipe the inlet and outlet of the circulation pump to the piping system. Ensure that the pump outlet is on the boiler inlet side of the piping system. Pipe the globe valve in parallel with the pump to allow throttling of the flow rate.

3.4.7 Expansion Tanks

Some closed systems require an expansion tank.

3.4.8 Drain and Shut-off

All low points in the piping system should be equipped with drains. Provisions should be made for separate shut-off and drain valves on individual equipment so that the entire system does not have to be drained for service of a particular item.

3.4.9 Air Control and Venting

High points in the piping system should be vented with automatic or manual air vents.

3.4.10 Provisions for Dismantling

Utilization of unions on the inlet and outlet piping connections may simplify future service requirements.

3.4.11 Insulation

To conserve energy and protect personnel, hot piping loops should be insulated after testing for leaks.

3. Installation (cont.)

3.5 Electrical

The boiler must be wired by qualified personnel in strict compliance with all codes and regulations.

Refer to the wiring diagram included in paragraph 6.1 and any specific diagrams supplied.

3.5.1 Power Supply

With the boiler "On-off" switch in the "On" position and the main electrical supply open, connect the power feed lines from a fused disconnect or breaker

to the terminals marked L1, L2, and L3 of the boiler disconnect, breaker, or power splitter, whichever is supplied. See paragraph 6.1 for schematic diagram.

3.5.2 Grounding

The boiler must be properly grounded. Attach a suitable ground wire to the ground connection point in the control cabinet sized in accordance with national and local codes.

4. Start-Up and Operation

The following procedures should be performed in sequence to eliminate problems on start-up.

4.1 Start-up

It is presumed that all electrical wiring and plumbing has been checked prior to this start-up procedure.

4.1.1 Make sure that the hot water boiler valves and switches are in the following positions:

- | | |
|---------------------------------|--------|
| • Water Outlet | Open |
| • Water Inlet(s) | Open |
| • Drain Valve(s) | Closed |
| • Slowdown Valve(s) | Closed |
| • Water Make-up/Feed Water | Open |
| • Circulation Pump | Off |
| • Main Power | Off |
| • Service Loop Isolating Valves | Open |

4.1.2 Allow the boiler and system to completely fill and vent.

4.1.3 Adjust the temperature controller to its lowest setting, by turning the dial on the front of the control.

4.1.4 Make sure that the electrical control panel door is closed.

4.1.5 Ensure that the system (external to the boiler) is fully prepared for operation and that personnel are aware that the system is being started up.

4.1.6 Start the circulation pump (if included*). Adjust the flow rate through the system to the desired flow rate using the globe valve piped in parallel with the circulation pump.

*some sidearm systems do not require a pump.

4.1.7 Check the system piping for leaks.

4.1.8 The presence of air in the system is indicated by noise in the piping circuit. Any air should be vented before proceeding with the start-up. Air venting procedures may require repeating.

4.1.9 Move the boiler "On-Off" switch to the "On" position.

The green power light should be illuminated and the heating elements should energize provided that the low water level switch is not tripped.

If the red "low level" light is on, then the level sensor is detecting a low water level condition and will not energize the elements. When the boiler fills, the light should shut off and the elements will energize.

4.1.10 Simulate a low water condition by depressing the "push-to-test" button. The boiler contactors should open and the red "low level light" should illuminate.

The noise (caused by the contactors switching open) indicates that the elements have been turned off and the light indicates the control is working.

4.1.11 Set the temperature controller (by turning the dial on the front of the controller) to the desired temperature setting.

Note that the temperature control should be set lower than the high limit controller setting. The high limit controller is set to prevent exceeding the maximum allowable temperature as shown on the boiler nameplate.

4.1.12 Set the temperature differential (by removing the controller cover and turning the small dial on the side) to the minimum setting. Note that fine tuning of the temperature control may be required for your specific application.

4.1.13 The pointers on the pressure/temperature gauge (at the outlet of the boiler) should begin to rise until the temperature reaches the set point of the temperature controller. At this point, the controller will de-energize the heaters.

4.1.14 Do a final check for leaks and functionality of the boiler and system.

4.1.15 The system should now be operational.

4.1.16 It is not normally necessary to pre-boil water to clean the heating elements or the interior of the vessel. They have already been semi-cleaned prior to installation and there is no excessive grease or oil inside the boiler.

However, if super-clean conditions make pre-boiling necessary, ensure that the detergents used are not harmful

4.0 Start-Up and Operation (cont.)

4.2 Operation

- 4.2.1 If a proper maintenance schedule is followed, all that is required is to turn the boiler on for it to function normally. Before restarting the boiler repeat 4.1 as required.
- 4.2.2 Although the boiler can operate safely unattended, it is best to shut the boiler down when it is not required over evenings, weekends or other prolonged periods. This will save energy.
- 4.2.3 Water treatment may be necessary in some hard water areas, since excessive scale buildup on internal boiler components will result in heating element failure and costly repairs. Refer to paragraph 5.4 for a discussion on this subject.

5.0 Maintenance

Sussman hot water boilers, when properly maintained, will provide many years of trouble free service. To establish a good preventative maintenance program, it is recommended that the following maintenance procedures be adhered to.

5.1 Electrical Verification



To avoid risk of electrical shock, disconnect the power supply to the boiler prior to and during electrical servicing.

- 5.1.1 All electrical connections in the power circuit should be inspected and re-tightened periodically.
- 5.1.2 Every four months, the following verifications are to be made.
- Check the operation of the low water cutoff control by using the "Push-to-test" button. When depressed, all energized heating circuits should immediately go off until the button is released.
 - Remove, clean and reinstall all controller electrodes. If more than one electrode is supplied, to ensure that the wires are re-connected to the correct terminals, we recommend that the first electrode be removed, cleaned and reinstalled; then the second and so on.
 - Check all fuses for continuity.
 - Visually inspect all contactors for signs of overheating.
 - Ensure that all electrical connections are tight.

5.2 Mechanical Verification

5.2.1 Scale Build-Up

Regularly inspect the heating elements through the manhole or hand-hole. Maintenance frequency will depend on water conditions and operating conditions.

6.0 Drawings and Literature

6.1 Drawings

The following mechanical and electrical drawings have been included in this manual:

Boiler Assembly Electrical Schematic

6.2 Literature

The following manufacturers' literature, as required, may be included with this manual.

T678B Dual bulb two stage temperature controller	Honeywell	T675A,B; T687A temperature controllers	Honeywell
T475A Outdoor reset control	Honeywell	T991 A Proportional temperature controller	Honeywell
L4008A,B,E,I; L6008A,G,H Aquastat® controllers	Honeywell	T991 B Proportional temperature controller	Honeywell
T775A,B,C,D Remote temperature controller & Addendum	Honeywell	F61 Series standard flow rate switch	Johnson Controls

8.0 Troubleshooting Guide

8.1 Failed Heaters

Sussman boiler flange heaters are of the highest quality. When properly maintained, they should provide many years of service.

All heaters undergo a series of rigorous mechanical and electrical inspections.

In the event that a heater fails, **it is likely that the cause is** low water or scale build-up condition.

Multiple coincident failures are almost certainly the result in a low water condition.

Keep in mind that if new heaters are installed in a boiler where the cause of failure has not been corrected, they too may fail.

8.1 Trouble Shooting Guide

Check Points	Boiler Problems												
	1 "System On" pilot light does not illuminate	2 Low water condition	3 High limit condition	4 Heater fuses fail	5 Main fuses blown	6 Does not fill	7 Leaks water	8 Reset button trips	9 Does not heat	10 Will not reach set temperature	11 Pressure relief valve opens	12 Heaters continually burn out	13 Does not maintain temperature
Pilot light burnt out	x												
Faulty on-off switch	x							x	x				
Breaker reset	x							x	x				
Main power switch	x				x				x				
Main power fusing	x				x				x				
Flange heater failed				x	x				x	x			x
Magnetic contactor				x	x			x	x	x			
Electrodes & relay		x		x				x	x			x	
Temperature controller			x					x	x	x			x
Staging switch			x					x	x	x			x
Pressure relief valve		x				x	x				x		
Pressure gauge										x			x
Outlet valve closed			x								x		
Air in system		x	x			x					x		
High limit controller			x					x	x	x	x		
Scale buildup											x	x	
Heater fuse				x					x	x			x
Control transformer	x							x	x				
Control circuit wiring	x		x					x	x				
Power circuit wiring	x			x	x				x				
Supply voltage too high			x	x	x			x					
Supply voltage too low	x								x	x			
System undersized									x			x	
Leak at heater flange		x											
Piping leak		x											
Inlet valve closed		x	x										

9.0 Warranty

Sussman for their equipment, a copy of which has been included as part of the important documents included with the boiler. Any questions should be referred to Sussman.